

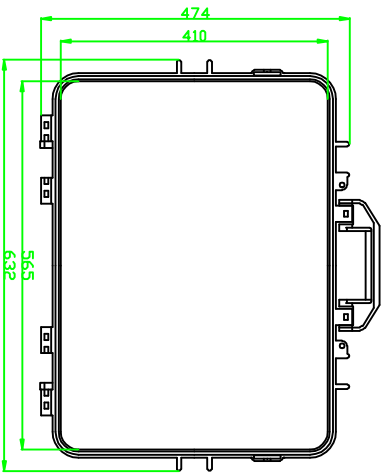

BASIC SIZE	0-3	>3-6	>6-10	>10-18	>18-30	>30-50	>50-80	>80-120	>120-180	>180-250
DIMS TOLERANCE	±0.14	±0.18	±0.22	±0.27	±0.33	±0.39	±0.46	±0.54	±0.63	±0.72

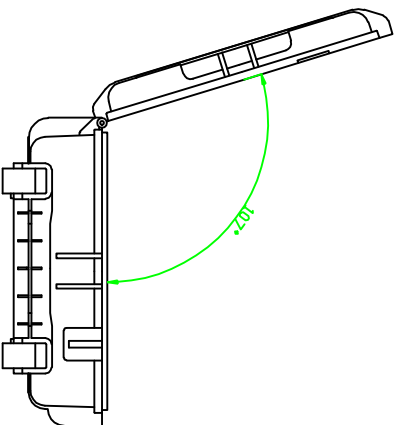
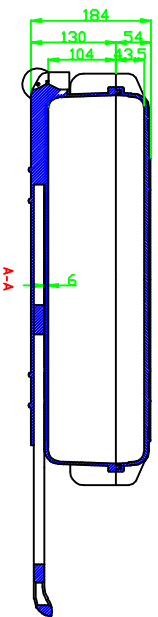
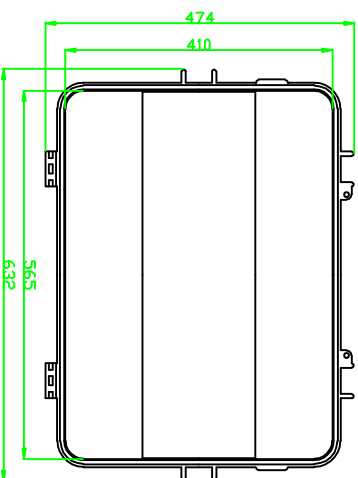
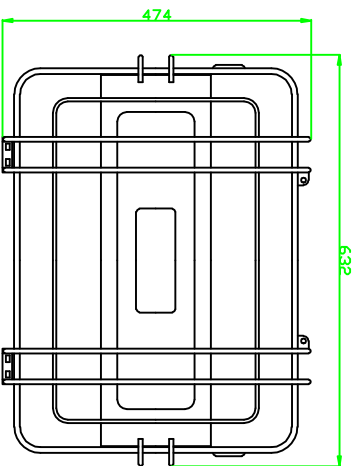
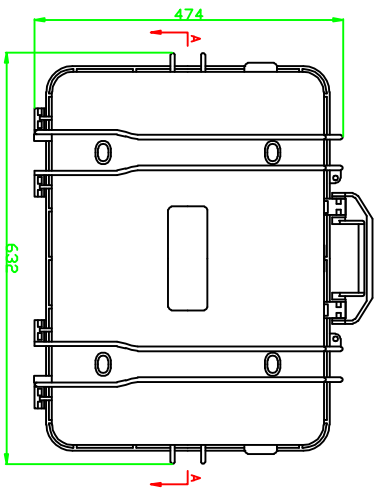

THE MACHINING TOLERANCES		NAME	DATE	 DRX.EVEREST WWW.EVERESTCASE.COM	
UNSPECIFIED TOLERANCES FOLLOW GB/1804-1992 IT13		DRAWN	CHECKED		
FDM TOLERANCES	±3mm	ENG APPR		TITLE	EVEREST CASE
THE ANGLE TOLERANCES	±1°	QTY	* 1	MATERIAL	ABS
FIRST ANGLE PROJECTION		SCALE	1:1	UNIT	mm
		DD NDT SCALE DRAWING		/PART NO	EP021-1B
				SHEET 1	OF 1